



## OCS-A-SERIES CRANE SCALES 1 – 20 TON

Simple and effective Crane Scale for weighing hanging loads

### FEATURES

- CE approved
- 30mm LED display, LCD (optional)
- Gross/Net weight display convertible
- Weight accumulation function
- Auto shut off
- Remote control calibration
- HOLD function
- AC/DC power adaptor: output DC9V/1.5A
- Infrared remote controller, distance: 10m
- kg/lb units (optional)
- Aluminium shell

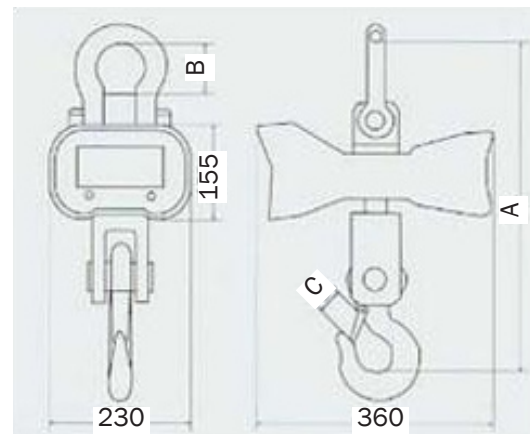

### SPECIFICATIONS

<b>Weight accuracy:</b>	As OIML III standard.
<b>Continuous working:</b>	100 hours(LCD);60 hours(LED)
<b>Safe overload:</b>	120%F.S.
<b>Operating temp:</b>	- 10°C ~ + 40°C
<b>Operating humidity:</b>	<= 90%R.H.

MODEL	CAPACITY	DIVISION	N.W. (KG)	A (MM)	B (MM)	C (MM)
OCS-A	1t	0.5kg	12	420	65	35
OCS-A	2t	1kg	14	600	80	45
OCS-A	3t	1kg	14	600	80	45
OCS-A	5t	2kg	24	730	100	55
OCS-A	10t	5kg	44	850	120	70
OCS-A	20t	10kg	65	900	140	70